



# MODEL H6151-54 HEAT SEALING MACHINES INSTRUCTION SHEET

## Introduction

The Model H6151-54 provides a strong air and water tight seal using polyethylene or polypropylene plastic bags.

## Specifications

Model	H6151	H6152	H6153	H6154
Power	200W	300W	400W	1000W
Seal Length	100mm	200mm	300mm	400mm
Seal Width	2mm	2mm	3mm	3mm
Seal Thickness	0.2mm	0.3mm	0.4mm	0.4mm
Heating Time	0.2-1.5 (sec)	0.2-1.5 (sec)	0.2-1.5 (sec)	0.2-2 (sec)
Dimensions	24 x 9 x 16cm	8 x 32 x 15cm	8.2 x 45 x 18cm	9.2 x 56 x 18cm
Weight	1.8kg	2.7kg	4.5kg	5.5kg

## Inventory (Figure 1)

## Qty

- A. Heat Sealing Machine ..... 1
- B. Teflon Fabric Strips ..... 2
- C. Heating Elements ..... 2

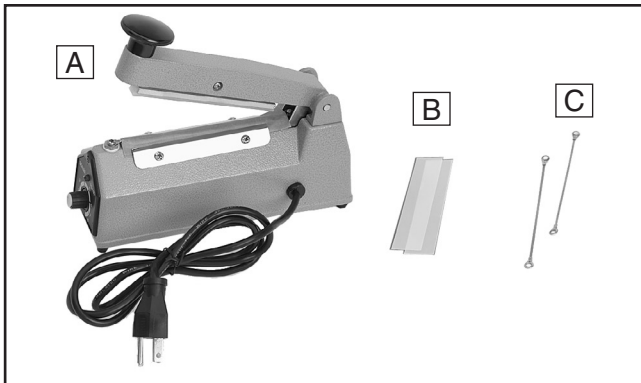

Figure 1. Model H6151 inventory.

## Operation

1. Remove the shipping brace, place the sealer on a level surface and connect it to a 110V AC power source.
2. Adjust the dial on the sealer (see **Figure 2**) according to the thickness and type of plastic bag.

Use a higher indicator setting for thick material and a lower setting for thin material.

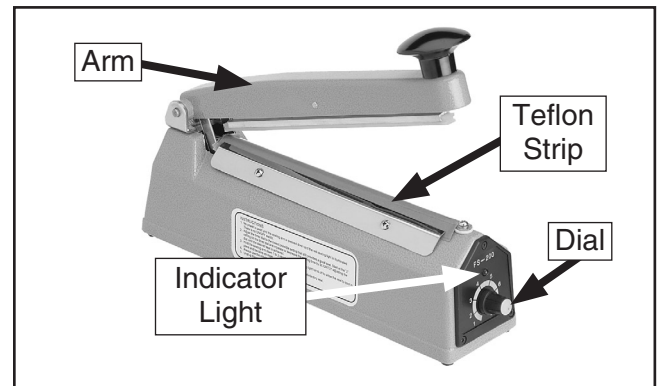

Figure 2. Model H6152 identification.

3. Open the arm, place the shortest width of the bag across the teflon strip and press the arm down. The red indicator light will illuminate.

**Note:** The sealer will not turn **ON** until you press the arm down. Therefore, you can leave it plugged into power between uses.

4. After the red light turns off, wait a second for the seal to cool, then raise the arm and remove the bag.

## 5. Check the seal.

—If the sealer leaves a 2-3mm wide band across the bag, the dial setting is correct.

—If the sealer did not leave an evenly melted band across the bag, go to the **Troubleshooting** section.

## Accessories

Grizzly carries bags for the Model H6151-54:

- H7291—Plastic Roll, 4" x 2", 150' x 2mil
- H7292—Plastic Roll, 8" x 2", 150' x 2mil
- H7293—Plastic Roll, 4" x 1,075' x 4mil
- H7294—Plastic Roll, 8" x 1,075' x 4mil
- H7295—Plastic Bag, 4" x 6" x 2mil, 100 Count
- H7296—Plastic Bag, 5" x 8" x 2mil, 100 Count
- H7297—Plastic Bag, 9" x 12" x 2mil, 100 Count
- H7298—Plastic Bag, 14" x 16" x 2mil, 100 Count
- H7299—Plastic Bag, 9" x 12" x 4mil, 100 Count
- H7300—Plastic Bag, 14" x 16" x 4mil, 100 Count

Grizzly cannot guarantee the compatibility of bags sold by other companies with the Model H6151-54.

## Maintenance

Occasionally the sealer will require cleaning.

1. **DISCONNECT THE SEALER FROM THE POWER** before performing maintenance!
2. Use an eraser, a dry cloth or a finger to remove residue from the top teflon strip and the rubber strip on the arm. Do not use solvents.

## Service

If the teflon strips become torn replace them and the heating element.

### To replace the teflon strips and heating element:

1. **DISCONNECT THE SEALER FROM THE POWER!**
2. Remove the metal plates, the teflon strips and the heating element. On Model H6151 and H6152, remove the screw at the front of the sealer that secures the heating element (see **Figure 3**).

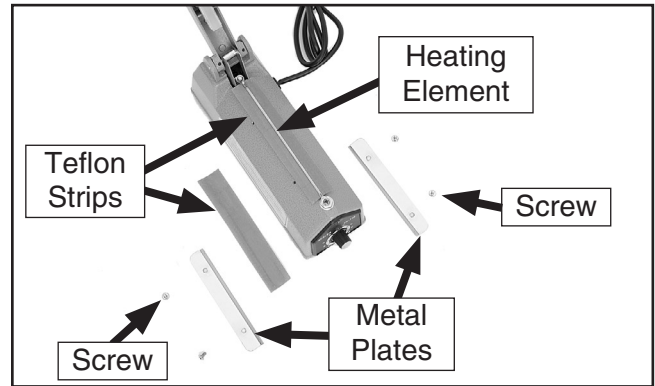

**Figure 3.** Teflon strips and heating element, Model H6151.

On Model H6153 and H6154, remove the front cover and push forward on the terminal assembly to release the heating element (see **Figure 4**).

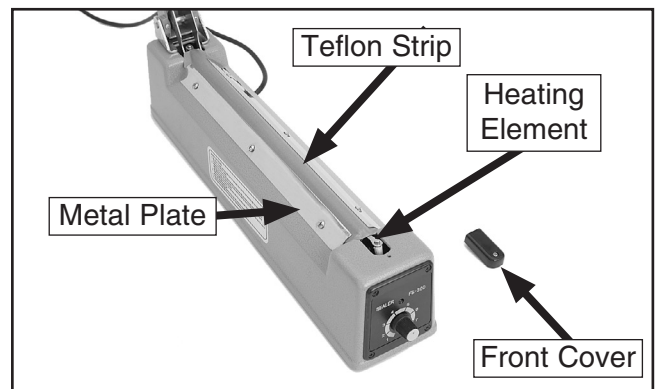

**Figure 4.** Teflon strips and heating element, Model H6153.

3. Install new teflon strips and a heating element—sandwich the element between the strips, and reinstall the metal plates.

## Troubleshooting

- If the sealer creates a partial seal, select a higher dial setting to increase the heating time.
- If the sealer melts through the bag or the bag sticks to the teflon strip, select a lower dial setting.
- If the bag sticks to the rubber strip on the arm, press the arm down longer after the red light switches off to increase the cooling time.

*If you need help with your new heat sealer, call our Tech Support at: (570) 546-9663.*



# Electrical Components & Wiring Diagram

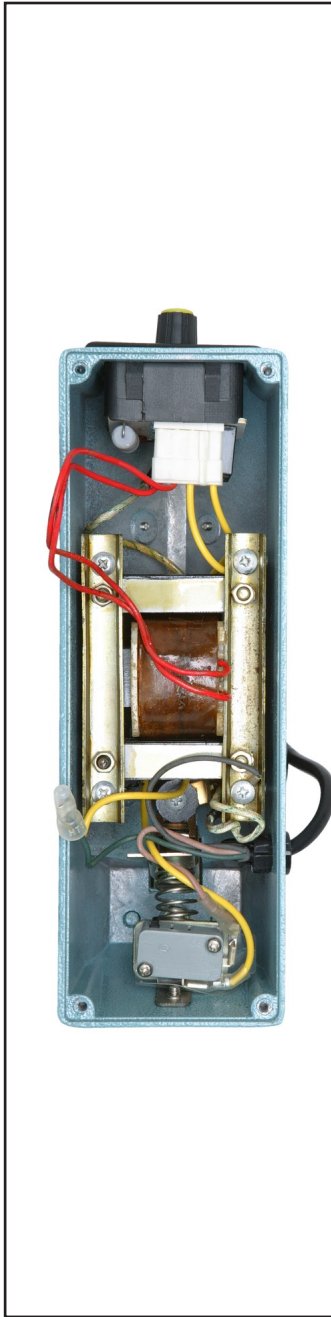

Figure 5. Model H6151.



Figure 6. Model H6152.



Figure 7. Model H6153.

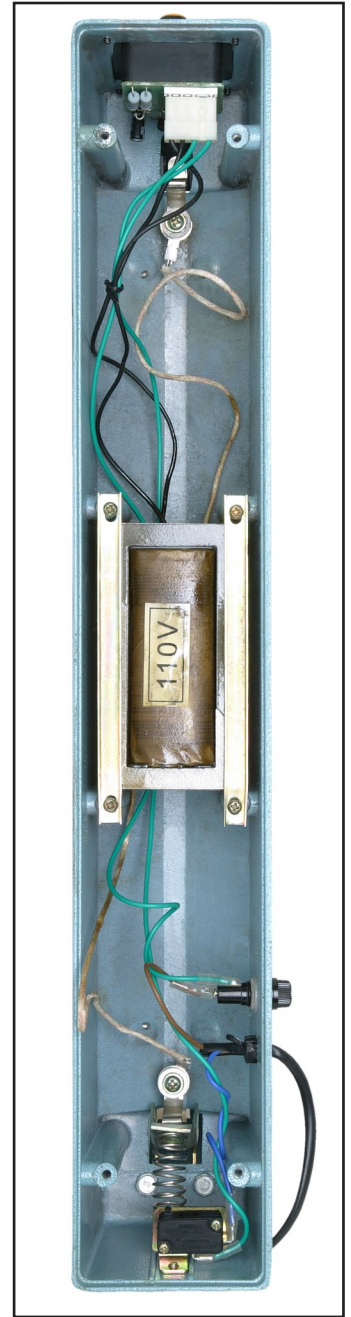

Figure 8. Model H6154.

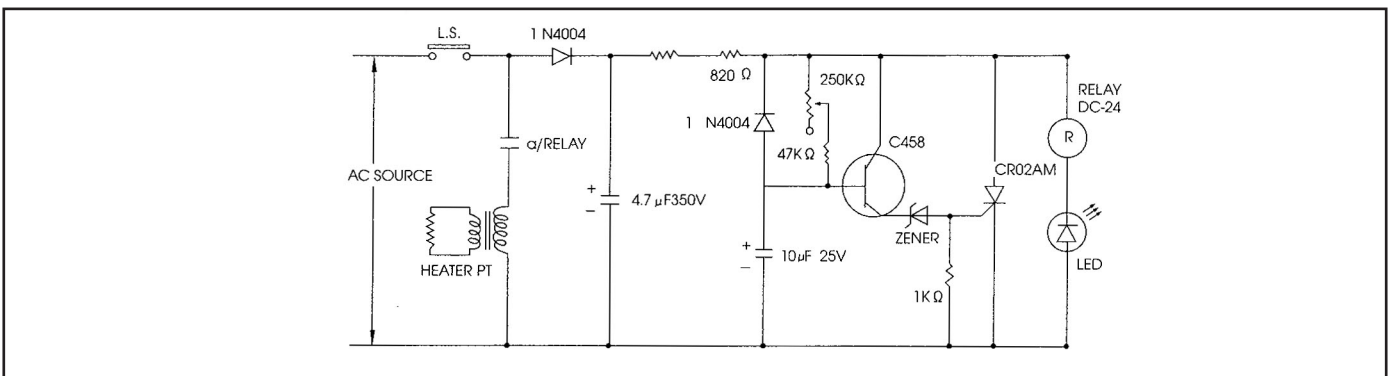
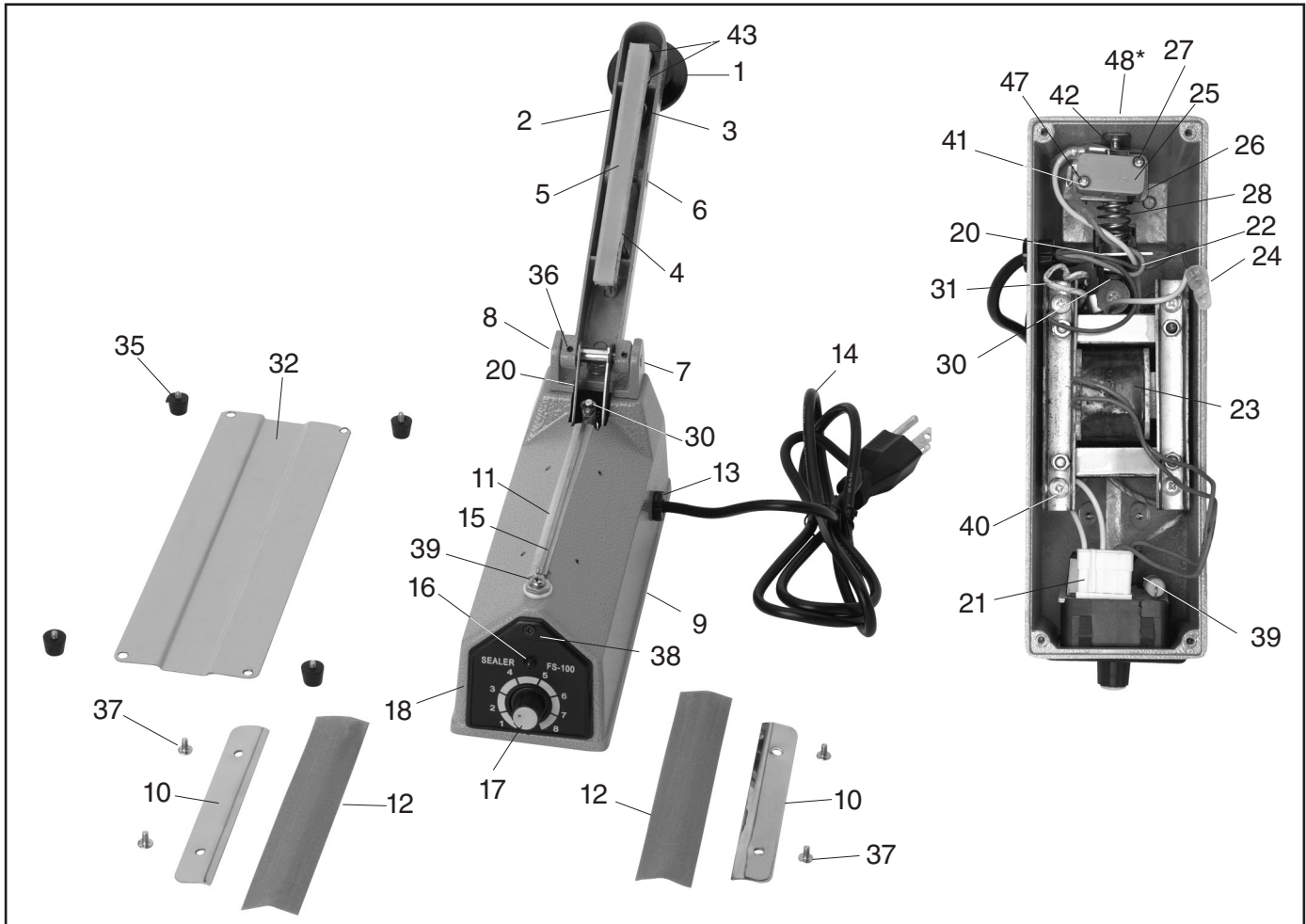

Figure 9. Model H6151-54 wiring diagram.



# H6151 Parts Breakdown & List



REF	PART #	DESCRIPTION
1	PH6151001	HANDLE KNOB
2	PH6151002	PLATEN ARM
3	PH6151003	PLATEN SPRING
4	PH6151004	PLATEN
5	PH6151005	SILICON RUBBER STRIP
6	PS01M	PHLP HD SCR M4-.7 X 18
7	PH6151007	HINGE
8	PH6151008	HINGE BRACKET
9	PH6151009	SEALER BASE
10	PH6151010	METAL PLATE
11	PH6151011	LOWER TEFLON ELEMENT
12	PH6151012	UPPER TEFLON CLOTH
13	PH6151013	STRAIN RELIEF
14	PH6151014	POWER CORD
15	PH6151015	HEATING ELEMENT
16	PH6151016	PILOT LAMP
17	PH6151017	TIMER KNOB
18	PH6151018	CONTROL PANEL ASSEMBLY
20	PH6151020	SWITCH LEVER
21	PH6151021	WIRE CONNECTOR
22	PH6151022	INTERNAL WIRING

REF	PART #	DESCRIPTION
23	PH6151023	HEATER TRANSFORMER
24	PH6151024	WIRE CONNECTOR
25	PH6151025	MICROSWITCH
26	PH6151026	SWITCH BRACKET
27	PH6151027	SWITCH INSULATION
28	PH6151028	SWITCH LEVER SPRING
30	PH6151030	HEATER TERMINAL ASSEMBLY
31	PH6151031	GROUNDING WIRE
32	PH6151032	COVER PLATE
35	PH6151035	RUBBER FOOT AND SCREW
36	PSS81M	SET SCREW M3-.5 X 5
37	PS12M	PHLP HD SCR M3-.5 X 6
38	PFH57M	FLAT HD SCR M3-.5 X 8
39	PS17M	PHLP HD SCR M4-.7 X 6
40	PS18M	PHLP HD SCR M4-.7 X 25
41	PS59M	PHLP HD SCR M3-.5 X 14
42	PS07M	PHLP HD SCR M4-.7 X 8
43	PSB04M	CAP SCREW M6-1 X 10
47	PLW09M	LOCK WASHER 3MM
48*	PTLW01M	EXT TOOTH WASHER 4MM

\* Part not shown in breakdown



# H6152 Parts Breakdown & List

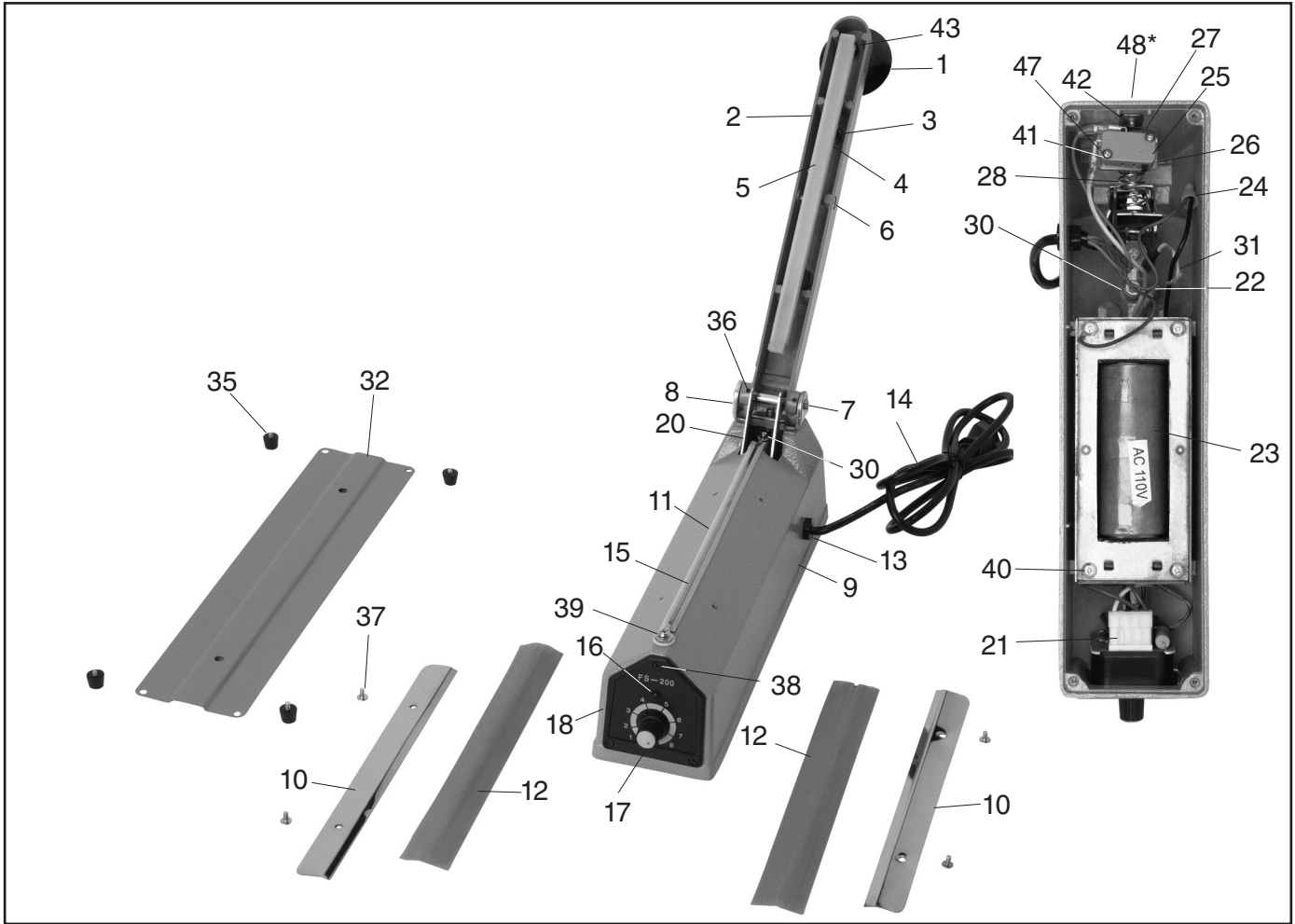

REF	PART #	DESCRIPTION
1	PH6152001	HANDLE KNOB
2	PH6152002	PLATEN ARM
3	PH6152003	PLATEN SPRING
4	PH6152004	PLATEN
5	PH6152005	SILICON RUBBER STRIP
6	PH6152006	SPECIAL PHLP HD SCR M5-.8 X 25
7	PH6152007	HINGE
8	PH6152008	HINGE BRACKET
9	PH6152009	SEALER BASE
10	PH6152010	METAL PLATE
11	PH6152011	LOWER TEFLON ELEMENT
12	PH6152012	UPPER TEFLON CLOTH
13	PH6152013	STRAIN RELIEF
14	PH6152014	POWER CORD
15	PH6152015	HEATING ELEMENT
16	PH6152016	PILOT LAMP
17	PH6152017	TIMER KNOB
18	PH6152018	CONTROL PANEL ASSEMBLY
20	PH6152020	SWITCH LEVER
21	PH6152021	WIRE CONNECTOR
22	PH6152022	INTERNAL WIRING

REF	PART #	DESCRIPTION
23	PH6152023	HEATER TRANSFORMER
24	PH6152024	WIRE CONNECTOR
25	PH6152025	MICROSWITCH
26	PH6152026	SWITCH BRACKET
27	PH6152027	SWITCH INSULATION
28	PH6152028	SWITCH LEVER SPRING
30	PH6152030	HEATER TERMINAL ASSEMBLY
31	PH6152031	GROUNDING WIRE
32	PH6152032	COVER PLATE
35	PH6152035	RUBBER FOOT AND SCREW
36	PSS81M	SET SCREW M3-.5 X 5
37	PS12M	PHLP HD SCR M3-.5 X 6
38	PFH57M	FLAT HD SCR M3-.5 X 8
39	PS17M	PHLP HD SCR M4-.7 X 6
40	PS18M	PHLP HD SCR M4-.7 X 25
41	PS59M	PHLP HD SCR M3-.5 X 14
42	PS07M	PHLP HD SCR M4-.7 X 8
43	PSB04M	CAP SCREW M6-1 X 10
47	PLW09M	LOCK WASHER 3MM
48	PTLW01M	EXT TOOTH WASHER 4MM

\* Part not shown in breakdown



# H6153 Parts Breakdown & List

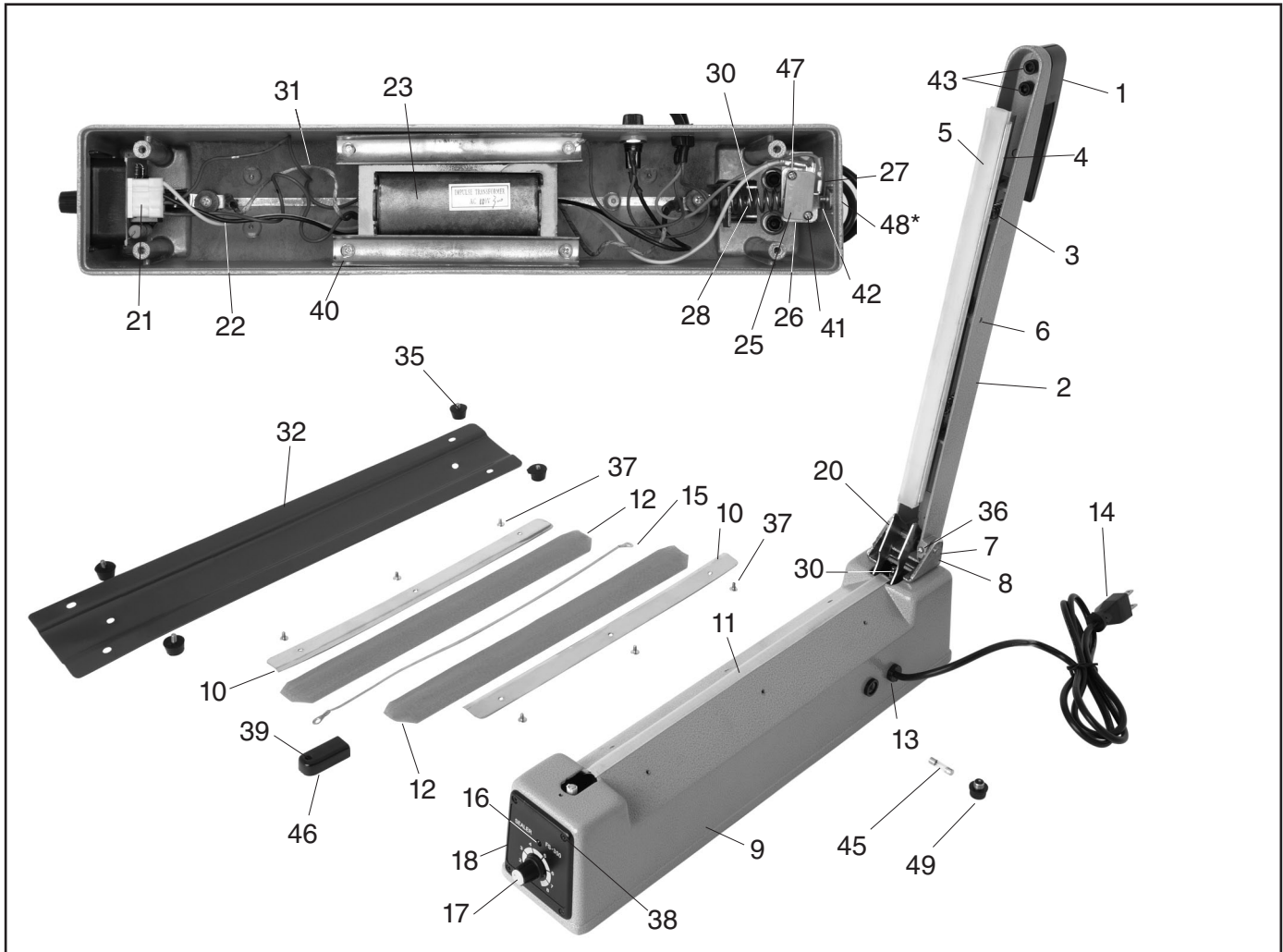

REF	PART #	DESCRIPTION
1	PH6153001	HANDLE KNOB
2	PH6153002	PLATEN ARM
3	PH6153003	PLATEN SPRING
4	PH6153004	PLATEN
5	PH6153005	SILICON RUBBER STRIP
6	PH6153006	SPECIAL PHLP HD SCR M5-.8 X 25
7	PH6153007	HINGE
8	PH6153008	HINGE BRACKET
9	PH6153009	SEALER BASE
10	PH6153010	METAL PLATE
11	PH6153011	LOWER TEFLON ELEMENT
12	PH6153012	UPPER TEFLON CLOTH
13	PH6153013	STRAIN RELIEF
14	PH6153014	POWER CORD
15	PH6153015	HEATING ELEMENT
16	PH6153016	PILOT LAMP
17	PH6153017	TIMER KNOB
18	PH6153018	CONTROL PANEL ASSEMBLY
20	PH6153020	SWITCH LEVER
21	PH6153021	WIRE CONNECTOR
22	PH6153022	INTERNAL WIRING
23	PH6153023	HEATER TRANSFORMER

REF	PART #	DESCRIPTION
25	PH6153025	MICROSWITCH
26	PH6153026	SWITCH BRACKET
27	PH6153027	SWITCH INSULATION
28	PH6153028	SWITCH LEVER SPRING
30	PH6153030	HEATER TERMINAL ASSEMBLY
31	PH6153031	GROUNDING WIRE
32	PH6153032	COVER PLATE
35	PH6153035	RUBBER FOOT AND SCREW
36	PS79M	PHLP HD SCR M3-.5 X 8
37	PS12M	PHLP HD SCR M3-.5 X 6
38	PFH57M	FLAT HD SCR M3-.5 X 8
39	PS55M	PHLP HD SCR M3-.5 X 10
40	PS21M	PHLP HD SCR M4-.7 X 15
41	PS59M	PHLP HD SCR M3-.5 X 14
42	PS07M	PHLP HD SCR M4-.7 X 8
43	PSB04M	CAP SCREW M6-1 X 10
45	PH6153045	FUSE
46	PH6153046	FRONT COVER
47	PLW09M	LOCK WASHER 3MM
48*	PTLW01M	EXT TOOTH WASHER 4MM
49	PH6153049	FUSE COVER

\* Part not shown in breakdown



# H6154 Parts Breakdown & List

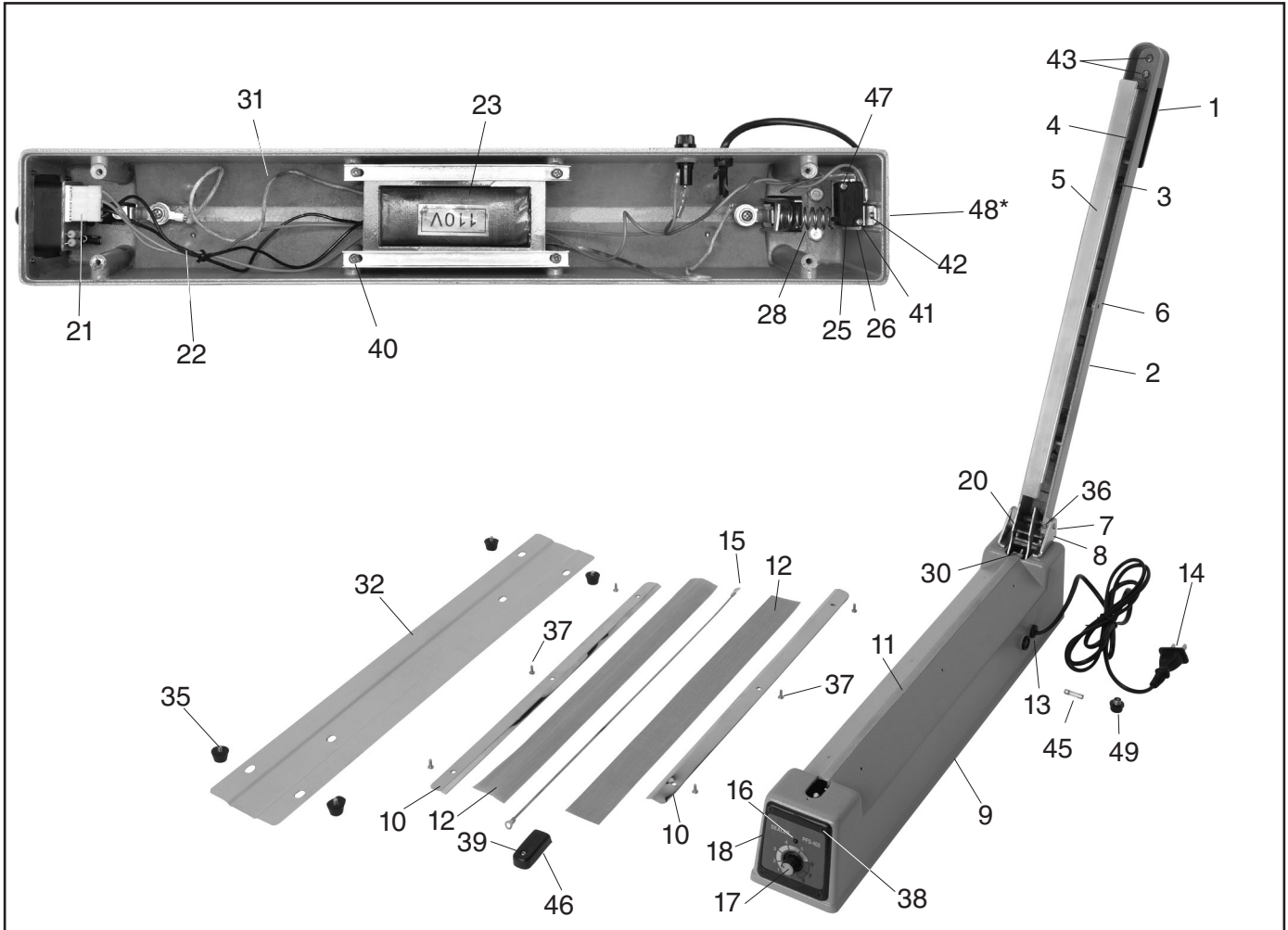

REF	PART #	DESCRIPTION
1	PH6154001	HANDLE KNOB
2	PH6154002	PLATEN ARM
3	PH6154003	PLATEN SPRING
4	PH6154004	PLATEN
5	PH6154005	SILICON RUBBER STRIP
6	PFH45M	FLAT HD SCR M5-.8 X 30
7	PH6154007	HINGE
8	PH6154008	HINGE BRACKET
9	PH6154009	SEALER BASE
10	PH6154010	METAL PLATE
11	PH6154011	LOWER TEFLON ELEMENT
12	PH6154012	UPPER TEFLON CLOTH
13	PH6154013	STRAIN RELIEF
14	PH6154014	POWER CORD
15	PH6154015	HEATING ELEMENT
16	PH6154016	PILOT LAMP
17	PH6154017	TIMER KNOB
18	PH6154018	CONTROL PANEL ASSEMBLY
20	PH6154020	SWITCH LEVER
21	PH6154021	WIRE CONNECTOR
22	PH6154022	INTERNAL WIRING

REF	PART #	DESCRIPTION
23	PH6154023	HEATER TRANSFORMER
25	PH6154025	MICROSWITCH
26	PH6154026	SWITCH BRACKET
28	PH6154028	SWITCH LEVER SPRING
30	PH6154030	HEATER TERMINAL ASSEMBLY
31	PH6154031	GROUNDING WIRE
32	PH6154032	COVER PLATE
35	PH6154035	RUBBER FOOT AND SCREW
36	PS55M	PHLP HD SCR M3-.5 X 10
37	PS79M	PHLP HD SCR M3-.5 X 8
38	PFH57M	FLAT HD SCR M3-.5 X 8
39	PS55M	PHLP HD SCR M3-.5 X 10
40	PS02M	PHLP HD SCR M4-.7 X 12
41	PS50M	PHLP HD SCR M3-.5 X 12
42	PH6154042	PHLP HD SCR M4-.7 X 5
43	PHTEK37M	TAP SCREW M5 X 12
45	PH6154045	FUSE
46	PH6154046	FRONT COVER
47	PLW09M	LOCK WASHER 3MM
48*	PTLW01M	EXT TOOTH WASHER 4MM
49	PH6154049	FUSE COVER

\* Part not shown in breakdown



# *grizzly.com*

**TOOL WEBSITE**

Buy Direct and Save with Grizzly® – Trusted, Proven and a Great Value!

*Visit Our Website Today And Discover  
Why Grizzly® Is The Industry Leader!*

- SECURE ORDERING
- ORDERS SHIPPED WITHIN 24 HOURS
- E-MAIL RESPONSE WITHIN ONE HOUR

-OR-

Call Today For A **FREE**  
Full Color Catalog

**1-800-523-4777**

